

## BD CALIPER BRAKE

In accordance with Nexen's established policy of constant product improvement, the specifications contained in this manual are subject to change without notice. Technical data listed in this manual are based on the latest information available at the time of printing and are also subject to change without notice.

Technical Support: 800-843-7445  
(651) 484-5900

[www.nexengroup.com](http://www.nexengroup.com)



# WARNING

Read this manual carefully before installation and operation.

Follow Nexen's instructions and integrate this unit into your system with care.

This unit should be installed, operated and maintained by qualified personnel **ONLY**.

Improper installation can cause injury or death.

Comply with all applicable codes.

MEX (55) 53 63 23 31 MTY (81) 83 54 10 18  
QRO (442) 1 95 72 60 [ventas@industrialmagza.com](mailto:ventas@industrialmagza.com)  
**INDUSTRIAL MAGZA**  
DIST. AUTORIZADO

Nexen Group, Inc.  
560 Oak Grove Parkway  
Vadnais Heights, Minnesota 55127

**ISO 9001 Certified**

Copyright 2000 Nexen Group, Inc.

FORM NO. L-20200-D-0106

# Table of Contents

Introduction	4
Installation	4
Air Connection-General	6
Lubrication	6
Maintenance	6
Parts Replacement	7
Parts List	8
Replacement Parts	8
Warranty	9

## INTRODUCTION

Read this manual carefully, making full use of its explanations and instructions. The “Know How” of safe, continuous, trouble free operation depends on the degree of your understanding of the system and your willingness to keep all components in proper operating condition. Pay particular attention to all **NOTES**, **CAUTIONS**, and **WARNINGS** to avoid the risk of personal injury or property damage. It is important to understand that these **NOTES**, **CAUTIONS**, and **WARNINGS** are not exhaustive. Nexen cannot possibly know or evaluate all conceivable methods in which service may be performed, or of the possible hazardous consequences of each method. Accordingly,

anyone who uses a procedure that is not recommended by Nexen must first satisfy themselves that neither their safety or the safety of the product will be jeopardized by the service method selected.

### WARNING

**The user(s) of this equipment must comply with operating procedures and training of operating personnel as stated in the Occupational Safety and Health Act (OSHA) Standard (29 CFR 1910) Section 1910.219-K.**

## INSTALLATION

### DISC

#### CAUTION

**Do not use lubricants when installing Disc and Q.D. Bushing.**

1. Thoroughly inspect the tapered bore of the Disc Hub, and the tapered surface of the Q.D. Bushing. Remove any dirt, grease, or foreign material.
2. Assemble Q.D. Bushing into Disc Hub, aligning untapped holes in Bushing Flange with tapped holes in Disc Hub.
3. Insert Pull-up Bolts, and alternately and evenly tighten them to the recommended torque (See Tables 1 and 2).

#### NOTE

**Runout is minimized if a dial indicator is used as the Pull-up bolts are tightened. Place the contact tip of the dial indicator on the machined surface of the rotor to measure runout. Runout should be 0.010 to 0.015 inch [2.5 to 3.8 mm] (See Fig. 1).**

#### CAUTION

**If excessive tightening torque is applied, bursting pressures are created in the hub. There must be a gap between the flange of the Q.D. bushing and the Disc Hub to ensure a proper press fit of the Q.D. bushing onto the shaft.**

5. To remove the Q.D. bushing, remove the Pull-up Bolts, then insert them into the threaded holes. Tighten the Pull-up bolts to push the Disc Hub off The Q.D. Bushing

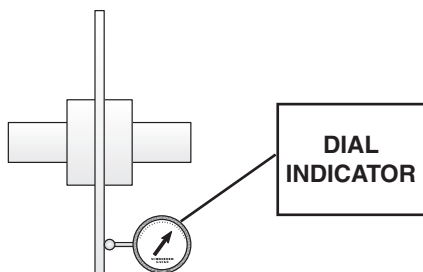

**FIGURE 1**

**TABLE 1  
PULL-UP BOLT TORQUES FOR NON-VENTILATED**

RECOMMENDED TIGHTENING TORQUES			
DIA.	PART NO.	Q.D. BUSHING	TORQUE
12"	934201	SF	30 ft. lbs. (40.5 Nm)
14"	934202	E	60 ft. lbs. (81 Nm)
16"	934203	E	60 ft. lbs. (81 Nm)
18"	934204	J	133 ft. lbs. (182.5 Nm)
20"	934205	J	133 ft. lbs. (182.5 Nm)
22"	934206	J	133 ft. lbs. (182.5 Nm)
24"	934207	J	133 ft. lbs. (182.5 Nm)

**TABLE 2  
PULL-UP BOLT TORQUES FOR VENTILATED DISCS**

RECOMMENDED TIGHTENING TORQUES			
DIA.	PART NO.	Q.D. BUSHING	TORQUE
18.25"	934200	J	135 ft. lbs. (182.5 Nm)
21"	934300	J	135 ft. lbs. (182.5 Nm)
24"	934400	J	135 ft. lbs. (182.5 Nm)

## MAIN FRAME

### NOTE

Set Screws (Item 50) and Nuts (Item 51) are provided for holding Arms (Items 2) in place when the "BD" Caliper Brake is used on vertical shaft installations (See Fig. 2).

1. Locate "BD" Caliper Brake in desired position in relation to the disc.
2. Align the support with the Main Frame (Item 1) mounting holes.

### NOTE

The support must be capable of sustaining loads produced during braking.

### NOTE

If shims are used under the Main Frame Mounting Pad, take care to prevent warping of the Main Frame when tightening the Main Frame Cap Screws (Item 19).

3. Tighten the Mounting Cap Screws to 50 ft. lbs. [67.8 N•m] torque.

### WARNING

The Mounting Cap Screws must sustain the loads produced by braking and the pre-load produced by the mounting torque. The torque rating specified above (50 ft. lbs. [67.8 N•m]) allows a significant load safety factor. **DO NOT OVER TORQUE.**

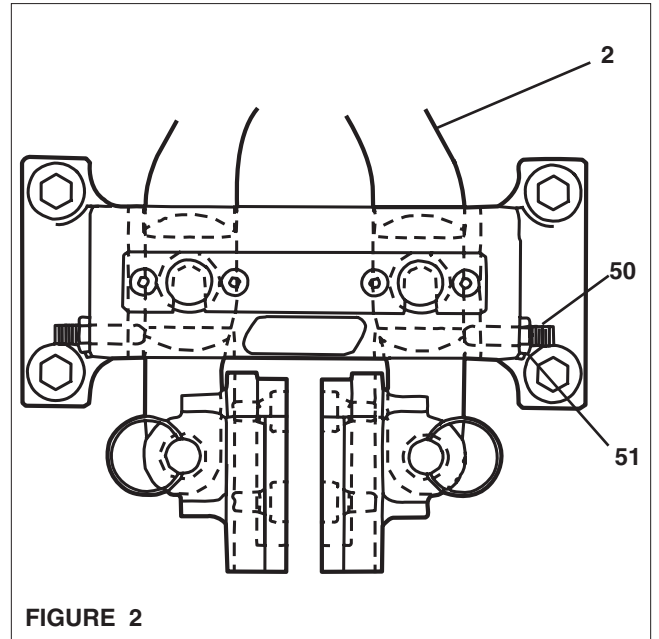

FIGURE 2

## ACTUATOR

The Actuator may be mounted on either side of the brake. The procedure for mounting the Actuator to the right or left side of the brake is as follows:

1. Pull Shoe Pins (Item 16) up and out (See Fig. 3).
2. Remove Shoes (Item 3) (See Fig. 3).
3. Remove four Cap Screws (Item 24) (See Fig. 3).
4. Remove Pivot Pin Retainer Plate (Item 6) (See Fig. 3).
5. Pry out Pivot Pins (Item 7) (See Fig. 3).
6. Slide Arms (Item 2) out of Main Frame (Item 1) (See Fig. 3).
7. Position Arms and Actuator as desired.
8. Reverse above procedure to reassemble "BD" Caliper Brake.
9. Tighten Pivot Pin Retaining Plate Cap Screws (Item 24)

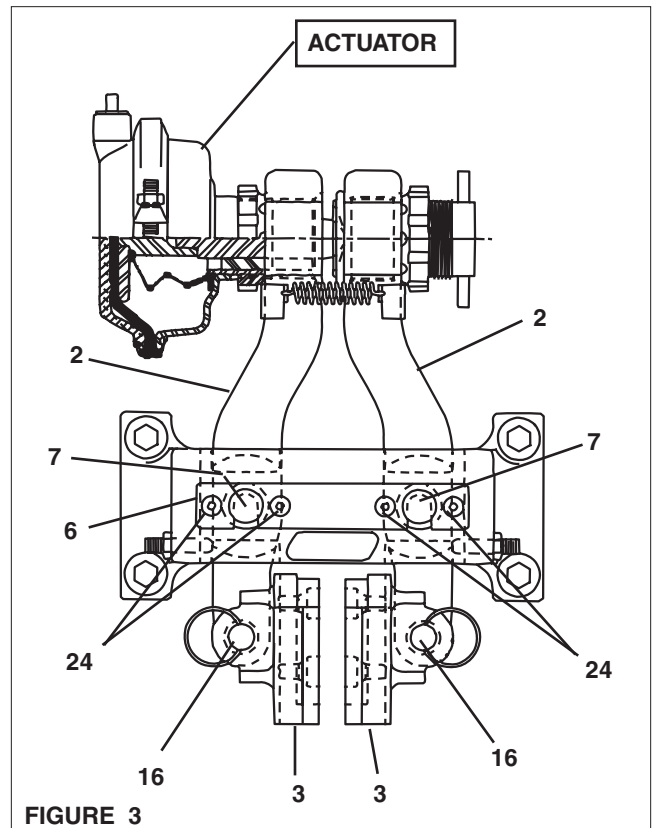

FIGURE 3

## FRICION FACING CLEARANCE ADJUSTMENT

1. Loosen Adjustment Screw Spanner Nut (Item 12) (See Fig. 4).
2. Back off Adjustment Screw (Item 8) until a 1/16" spacer can be slid between one Friction Facing (Item 14), and the disc.
3. Turn Adjustment Screw in until the spacer can be just pulled out.
4. Tighten the Adjustment Screw Spanner Nut (Item 12) to 10-14 ft. lbs. [13.6-19 N•m] torque.

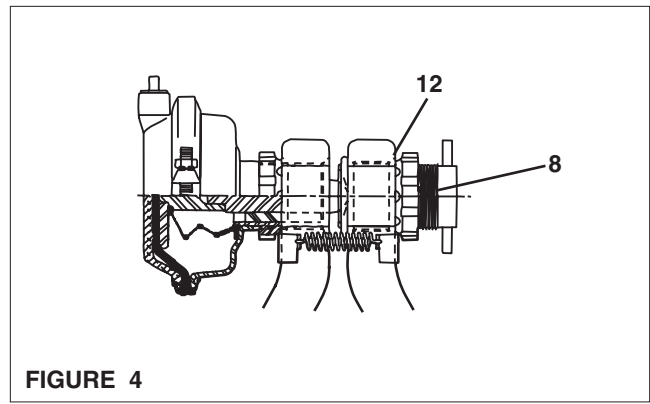

FIGURE 4

## AIR CONNECTION - GENERAL

Pneumatically actuated devices require clean, pressure regulated, and lubricated air for maximum performance, and long life. Your Nexen distributor carries filters, regulators, and lubricators specially designed to operate with Nexen Brakes.

The Actuator Air Connections may be rotated 360° by loosening the Ring Clamp and rotating the Actuator Head (See Fig. 5).

### NOTE

**Tighten Ring Clamp Bolts to 25-35 ft. lbs. [34-47 N•m]. torque.**

A Hose Assembly (Item 23) is supplied, and must be connected to the Brake with sufficient slack to allow the Actuator Arms (Item 2) full freedom of movement without putting stress on the hose couplings.

### WARNING

**Do not use rigid pipe or tubing when connecting directly to the Brake. Take care to prevent an unshielded air hose from rubbing on metal surfaces or edges, as this will cause rapid deterioration of the hose.**

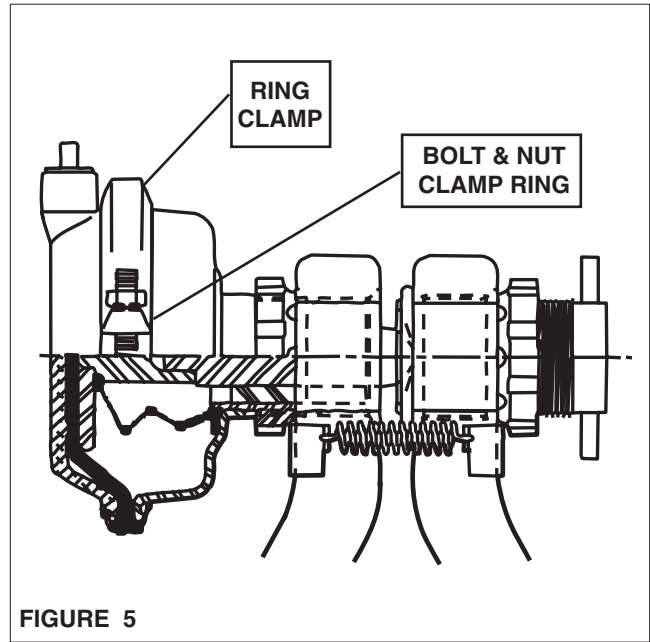

FIGURE 5

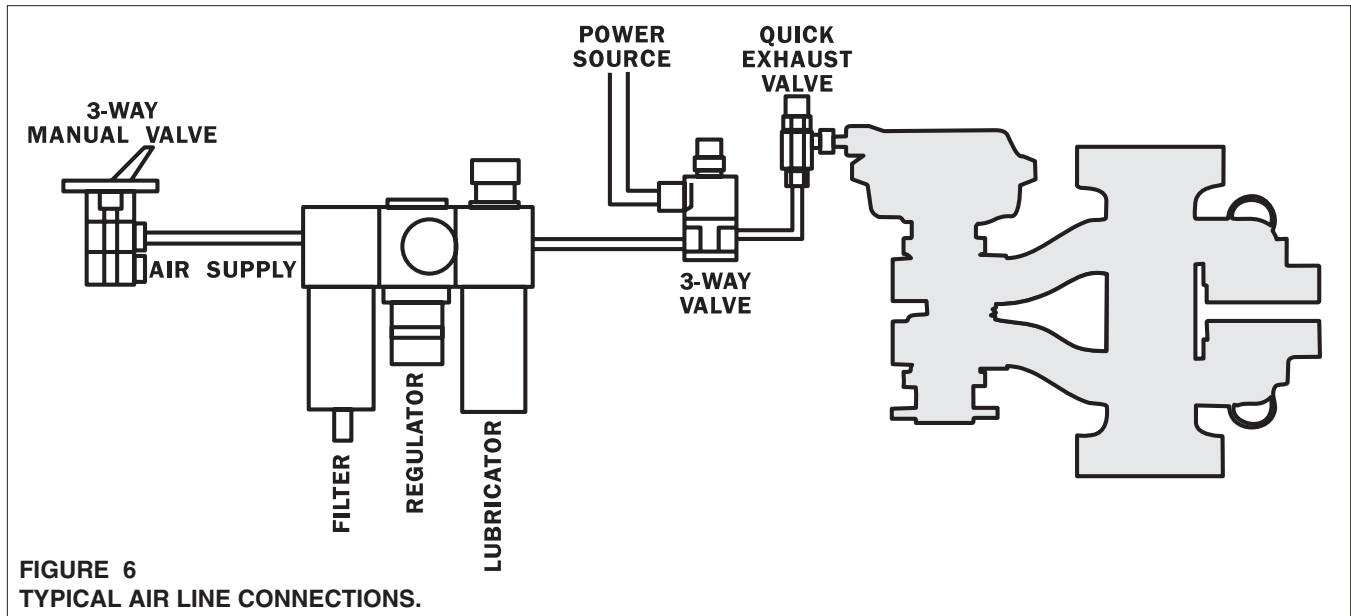

FIGURE 6  
TYPICAL AIR LINE CONNECTIONS.

## LUBRICATION

All pivot points on the “BD” Caliper Brake use self-lubricated, high PV bearings.

For tension control applications, where the disc is held at elevated temperatures for extended periods of time, use a light machine oil on Bearings (Items 14 & 15).

The sliding spherical contact between Adjustment Screw (Item 18), and Piston Rod (Item 10) should be lubricated with a molybdenum disulfide base grease.

## MAINTENANCE

1. Ensure that the following tightening torques are adhered to (See Table 3).
2. Check tightness of all air line connection, and condition of all air lines. Replace air lines if signs of deterioration exists.
3. Inspect Friction Facings for wear. Replace if worn to approximately 5/16" thick.
4. Lubricate items that require lubrication.

**TABLE 3**

ITEM	DESCRIPTION	TORQUE
----	Actuator Clamp Ring (Bolt & Nut)	25-35 ft.lbs. (33.7-47.2 Nm)
12	Spanner Nut	10-15 ft. lbs. (13.6-20.3 Nm)
18	Machine Screw	8-11 ft. lbs. (12-16 Nm)
19	Cap Screws	50 ft. lbs. (68 Nm)
----	Actuator Mounting Tube (Spanner Nut)	10-15 ft. lbs. (13.6-20.3 Nm)

## PARTS REPLACEMENT

### FRICITION FACING (Item 4)

#### NOTE

When replacing Friction Facings, inspect the Disc for scoring or grooves. If required, the Rotor Disc may be resurfaced. A total of 0.030" [ 0.762 mm.] may be removed from each side of the Disc before it is necessary to replace the Disc.

#### NOTE

The Machine Screws used to hold the Friction Facings have been assembled with an anaerobic compound. If removal is difficult, strike the end of the screwdriver with a hammer to break the crystalline structure of this compound before attempting to remove the screws.

1. Remove Shoe Pins (Item 16) to release Friction Facing Shoe assembly (Items 3, 4, & 5) from Arms (Item 2) (See Fig. 7).
2. Remove Friction Facings (Item 4) (See Fig. 7).
3. Install new Friction Facings using Screws (Item 18).
4. Loosen Adjustment Screw Spanner Nut (Item 12), then back out Adjustment Screw (Item 8) until Friction Facing Shoe Assembly will slide back into Arms (Item 2) (See Fig. 7).

5. Replace Friction Shoe Pins (Item 16) (See Fig. 7).
6. Perform Friction Facing Adjustment (See Page 2, “Friction Facing Clearance Adjustment”).

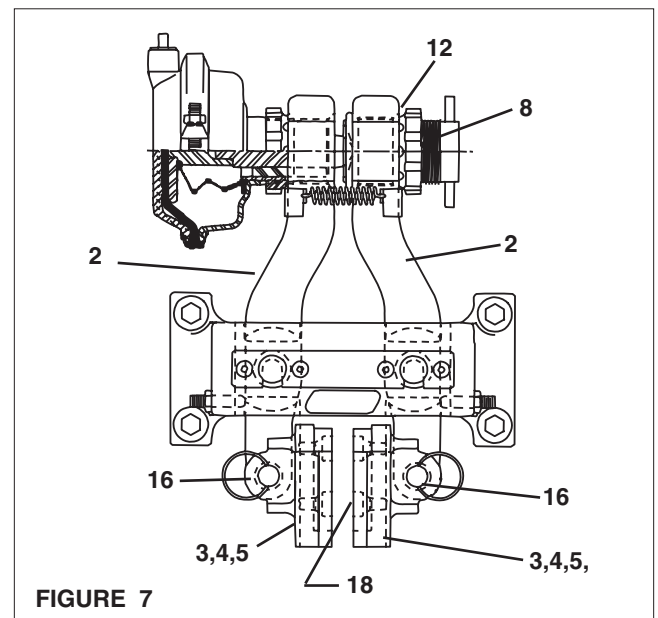

**FIGURE 7**

## HIGH PV BEARINGS (Items 14 & 15)

1. Loosen Adjustment Screw Spanner Nut (Item 12), and Adjustment Screw (Item 8) until Return Springs (Item 17) are free enough to be easily removed (See Fig. 8).
2. Remove Shoe Pins (Item 16), and Friction Facing Shoe Assembly (See Fig. 8).
3. Remove Pivot Pin Retaining Plate Screws (Item 24) and Retaining Plate (Item 6) (See Fig. 8).
4. Remove Pivot Pins (Item 7), and Arms (Item 2) from Main Frame (Item 1) (See Fig. 8).
5. Press out damaged Bearings (Item 14), and replace with new Bearings (See Fig. 8).
6. Ream new Bearings (Item 14) to fit Pivot Pins (Item 7).

7. Reassemble "BD" Brake.

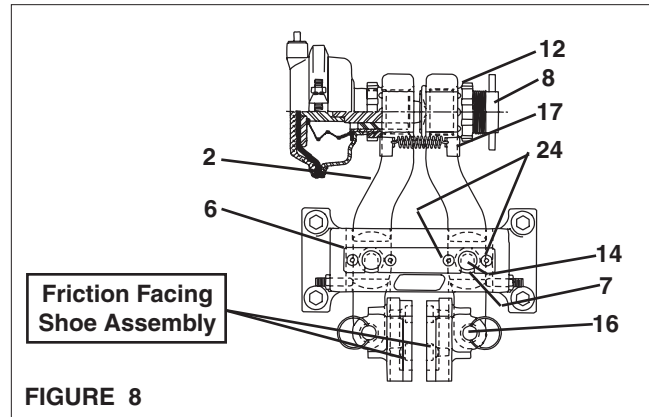

FIGURE 8

Item	Description	QTY
1	Main Frame	1
2	Brake Arm	2
3	Brake Shoe	2
4	Friction Facing*	2
5	Spring Clip	2
6	Retaining Pin Plate	1
7	Pivot Pin	2
8	Adjusting Screw	1
9	Retaining Ring	1
10	Piston Rod	1
11	Actuator Assembly**	1
12	Spanner Nut	1
14	Sleeve Bearing	4
15	Sleeve Bearing	4
16	Detent Pin	2
17	Extension Spring	2
18	Facing Screw	8
19	Cap Screw	4
20	Lock Washer	4
22	Fitting	1
23	Hose Assembly	1
24	Cap Screw	4
25	Bushing Fitting	1
26	Grooved Pin	1
50	Set Screw	2
51	Hex Nut	2

\* Friction Facing Kit #837473

\*\* Air Actuator Assembly #10474, Spring Actuator Assembly #10493.

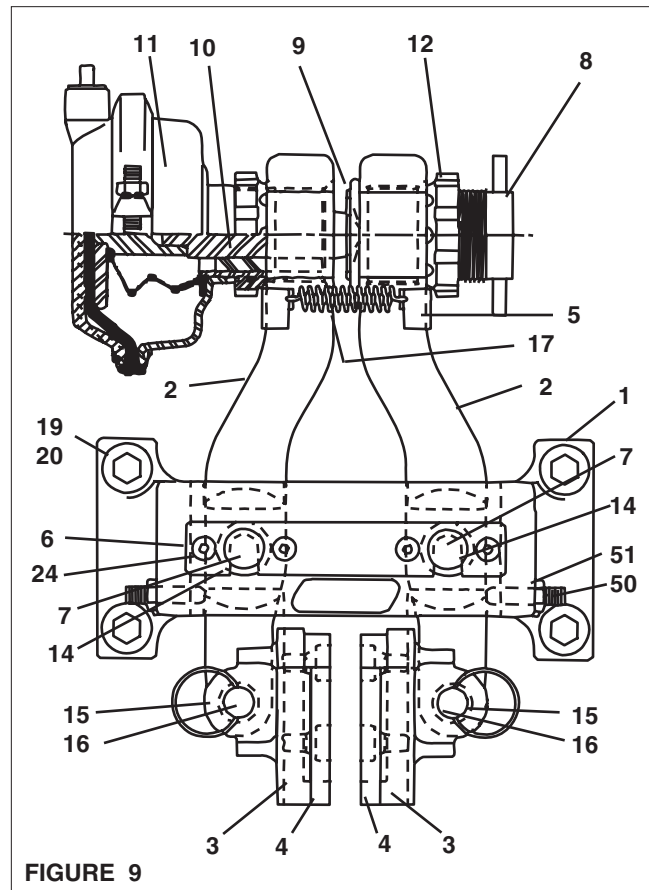

FIGURE 9

## REPLACEMENT PARTS.

The Item or "Balloon" Number for all Nexen Products is used for part identification on all Product Parts List, Product Price List, Unit Assembly Drawings, Bills of Materials, and Instruction Manuals.

When ordering replacement parts, specify model designation, item number, part description, and quantity.

Purchase replacement parts through your local Nexen Distributor.



## WARRANTY

### Warranties

Nexen warrants that the Products will be free from any defects in material or workmanship for a period of 12 months from the date of shipment. NEXEN MAKES NO OTHER WARRANTY, EXPRESS OR IMPLIED, AND ALL IMPLIED WARRANTIES, INCLUDING WITHOUT LIMITATION, IMPLIED WARRANTIES OF MERCHANTABILITY AND FITNESS FOR A PARTICULAR PURPOSE ARE HEREBY DISCLAIMED. This warranty applies only if (a) the Product has been installed, used and maintained in accordance with any applicable Nexen installation or maintenance manual for the Product; (b) the alleged defect is not attributable to normal wear and tear; (c) the Product has not been altered, misused or used for purposes other than those for which it was intended; and (d) Buyer has given written notice of the alleged defect to Nexen, and delivered the allegedly defective Product to Nexen, within one year of the date of shipment.

### Exclusive Remedy

The exclusive remedy of the Buyer for any breach of the warranties set out above will be, at the sole discretion of Nexen, a repair or replacement with new, serviceably used or reconditioned Product, or issuance of credit in the amount of the purchase price paid to Nexen by the Buyer for the Products.

### Limitation of Nexen's Liability

TO THE EXTENT PERMITTED BY LAW NEXEN SHALL HAVE NO LIABILITY TO BUYER OR ANY OTHER PERSON FOR INCIDENTAL DAMAGES, SPECIAL DAMAGES, CONSEQUENTIAL DAMAGES OR OTHER DAMAGES OF ANY KIND OR NATURE WHATSOEVER, WHETHER ARISING OUT OF BREACH OF WARRANTY OR OTHER

BREACH OF CONTRACT, NEGLIGENCE OR OTHER TORT, OR OTHERWISE, EVEN IF NEXEN SHALL HAVE BEEN ADVISED OF THE POSSIBILITY OR LIKELIHOOD OF SUCH POTENTIAL LOSS OR DAMAGE. For all of the purposes hereof, the term "consequential damages" shall include lost profits, penalties, delay images, liquidated damages or other damages and liabilities which Buyer shall be obligated to pay or which Buyer may incur based upon, related to or arising out of its contracts with its customers or other third parties. In no event shall Nexen be liable for any amount of damages in excess of amounts paid by Buyer for Products or services as to which a breach of contract has been determined to exist. The parties expressly agree that the price for the Products and the services was determined in consideration of the limitation on damages set forth herein and such limitation has been specifically bargained for and constitutes an agreed allocation of risk which shall survive the determination of any court of competent jurisdiction that any remedy herein fails of its essential purpose.

### Limitation of Damages

In no event shall Nexen be liable for any consequential, indirect, incidental, or special damages of any nature whatsoever, including without limitation, lost profits arising from the sale or use of the Products.

### Warranty Claim Procedures

To make a claim under this warranty, the claimant must give written notice of the alleged defect to whom the Product was purchased from and deliver the Product to same within one year of the date on which the alleged defect first became apparent.

**nexen**<sup>®</sup>

Nexen Group, Inc.  
560 Oak Grove Parkway  
Vadnais Heights, MN 55127

800.843.7445  
Fax: 651.286.1099  
www.nexengroup.com

ISO 9001 Certified